



# Did You Know...

July 2019 Edition

## Featured Unit: Cold Storage AHU

Contact us:  
sales@xetexinc.com

From the big to the small, we've got you covered. The custom packaged air handling unit highlighted this month is a 100% recirculation unit used by an automotive industry supplier in their finished goods storage room. The space is maintained at cooler temps to ensure longevity of their product before distribution. This unit cools the return air using an 8 row evaporator coil and air cooled R-410a refrigeration system discharging a refreshing 39.3 F. Try doing that with your standard catalog equipment!

### Unit highlights:

- Outdoor unit with 18ga painted acrylic exterior & 20ga galvanized interior
- 2" injected foam panels with thermal break construction
- DX cooling coil with stainless steel drain pan
- 100% recirculation cooling only unit
- 6.6 tons integral air cooled condensing
  - ◊ Direct drive ECM condensing fan
  - ◊ Low Ambient Kit
- Airfoil plenum fan with VFD
- Factory provided and fully programmed DDC controls



If you need assistance on any application you are currently working on please contact Xetex Sales at 612-724-3101 or email us at [sales@xetexinc.com](mailto:sales@xetexinc.com).

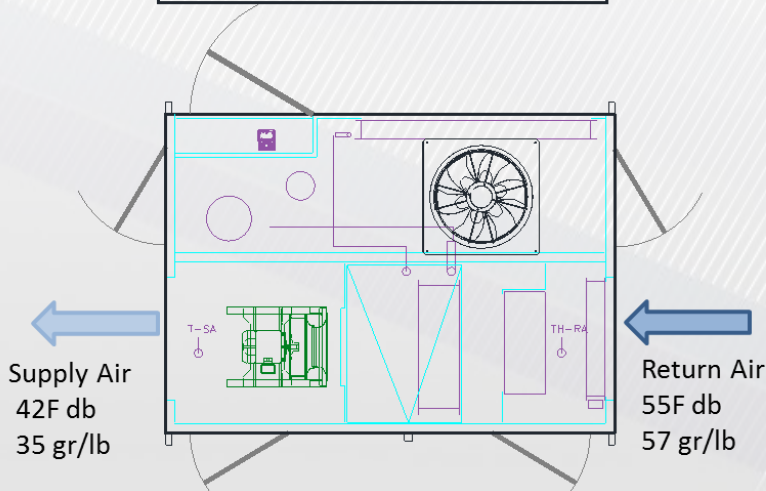
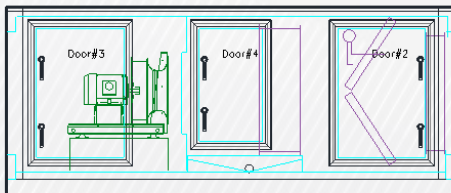

### MODEL: XAH-2500-RT-CD-AC

Height:	46"
Width:	78"
Length:	110"
Supply CFM:	2,500
Weight:	3200 lbs
Supply Air:	2500 CFM
Cool Type:	DX—Packaged
Cooling Capacity:	6.6 Tons
Entering DX Clg Temp:	55F db/ 53F wb
Leaving DX Clg Temp:	39F db / 39F wb