

Flat Plate Heat Exchanger Performance Curves

X08A ELEMENT

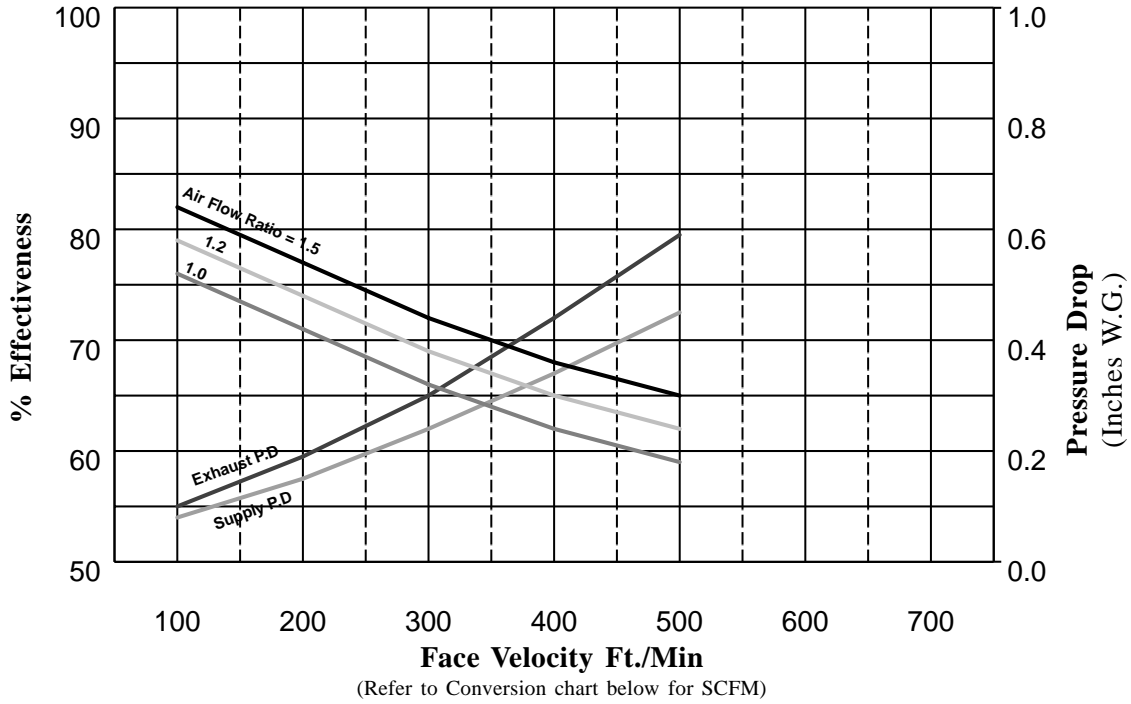

Conversion Chart - Airflow (SCFM) @ (Face Velocity x Face Area)

Size	(B) Length	(AxB) Face Area Sq. Ft.	Element Face Velocity					Wgt.
			100 ft/min	200 ft/min	300 ft/min	400 ft/min	500 ft/min	
X08A-4	3.94	0.16	16	32	47	63	79	7
X08A-6	5.91	0.26	26	51	77	102	128	13
X08A-10	9.84	0.45	45	90	135	181	226	17
X08A-16	15.75	0.74	74	149	223	298	372	22
X08A-18	17.72	0.84	84	168	253	337	421	30
X08A-24	23.62	1.14	114	227	341	454	568	35
X08A-30	29.53	1.43	143	286	429	572	714	39

Performance curves are based on standard conditions. For specific entering conditions, refer to Selection Procedures, pages 12 through 19.

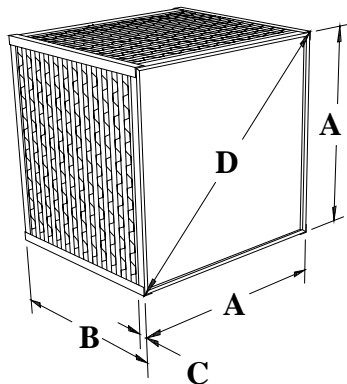

A = 7.9" (Height)
 C = 0.50" (Flange Dimension)
 D = 11.2"

Specifications and Dimensions are subject to change without notice.



Flat Plate Heat Exchanger Performance Curves

X12A ELEMENT

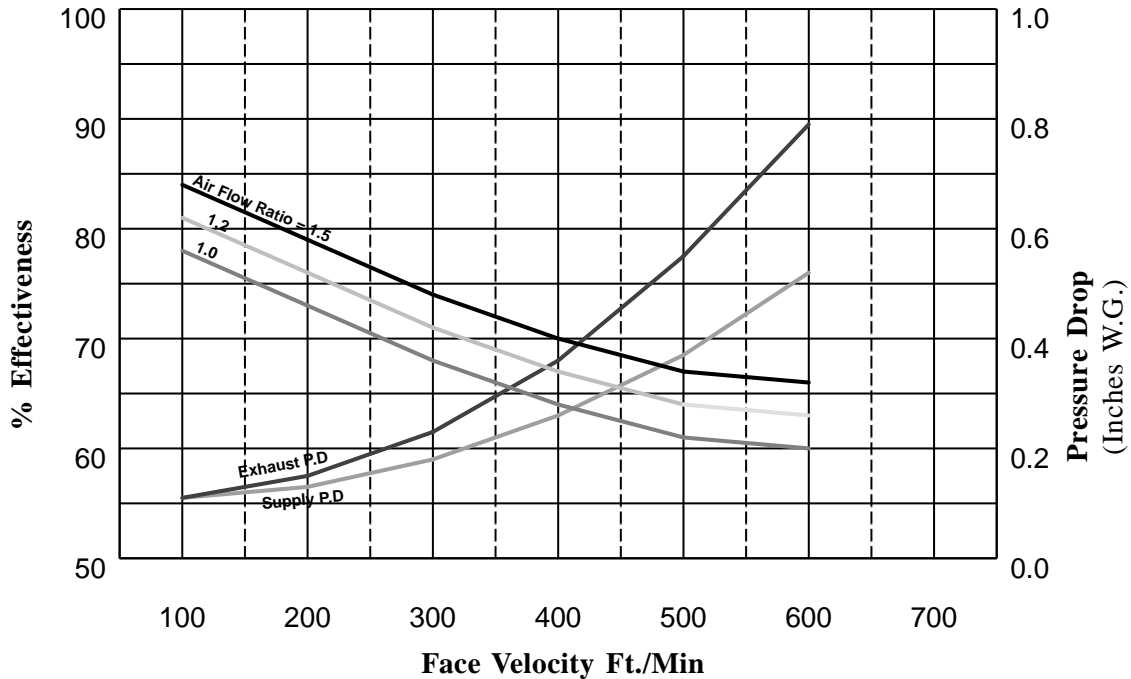

(Refer to Conversion chart below for SCFM)

Conversion Chart - Airflow (SCFM) @ (Face Velocity x Face Area)

Size	(B) Length	(AxB) Face Area Sq. Ft.	Element Face Velocity						Wgt.
			100 ft/min	200 ft/min	300 ft/min	400 ft/min	500 ft/min	600 ft/min	
X12A-6	5.91	0.37	37	74	110	147	184	221	7
X12A-12	11.81	0.81	81	162	243	324	405	487	13
X12A-18	17.72	1.25	125	251	376	502	627	752	17
X12A-24	23.62	1.70	170	339	509	679	848	1018	22
X12A-30	29.53	2.14	214	428	642	856	1070	1284	30
X12A-36	35.43	2.58	258	517	775	1033	1291	1550	35
X12A-42	41.34	3.03	303	605	908	1210	1513	1815	39

Performance curves are based on standard conditions. For specific entering conditions, refer to Selection Procedures, pages 12 through 19.

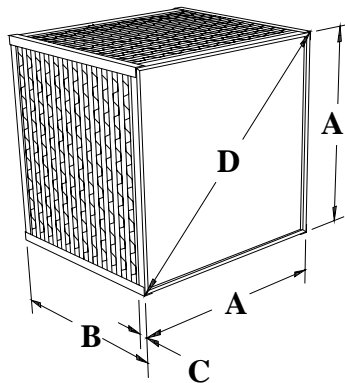

A = 11.8" (Height)
 C = 0.50" (Flange Dimension)
 D = 16.7"

Specifications and Dimensions are subject to change without notice.



Flat Plate Heat Exchanger Performance Curves

X14A ELEMENT

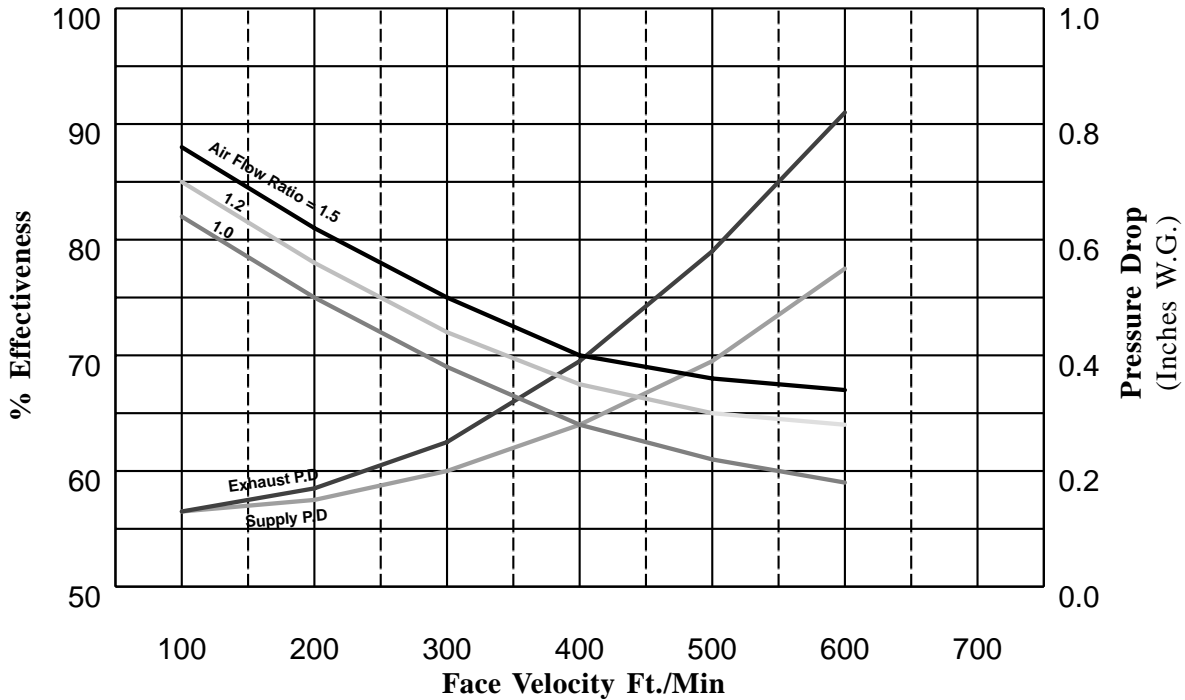

(Refer to Conversion chart below for SCFM)

Conversion Chart - Airflow (SCFM) @ (Face Velocity x Face Area)

Size	(B) Length	(AxB) Face Area Sq. Ft.	Element Face Velocity						Wgt.
			100 ft/min	200 ft/min	300 ft/min	400 ft/min	500 ft/min	600 ft/min	
X14A-6	5.91	0.44	44	87	131	174	218	262	7
X14A-12	11.81	0.96	96	192	288	384	481	577	15
X14A-18	17.72	1.49	149	297	446	594	743	892	20
X14A-24	23.62	2.01	201	402	603	804	1005	1207	25
X14A-30	29.53	2.54	254	507	761	1014	1268	1522	35
X14A-36	35.43	3.06	306	612	918	1224	1530	1837	40
X14A-42	41.34	3.59	359	717	1076	1434	1793	2151	45
X14A-48	47.25	4.11	411	822	1233	1644	2055	2466	51

Performance curves are based on standard conditions. For specific entering conditions, refer to Selection Procedures, pages 12 through 19.

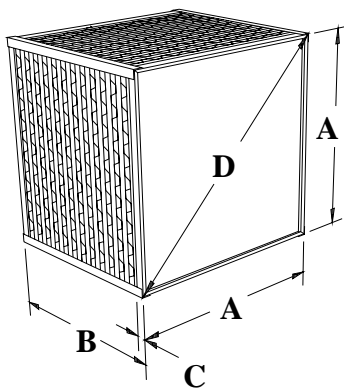

A = 13.8" (Height)
 C = 0.50" (Flange Dimension)
 D = 19.5"

Specifications and Dimensions are subject to change without notice.



Flat Plate Heat Exchanger Performance Curves

X20A ELEMENT

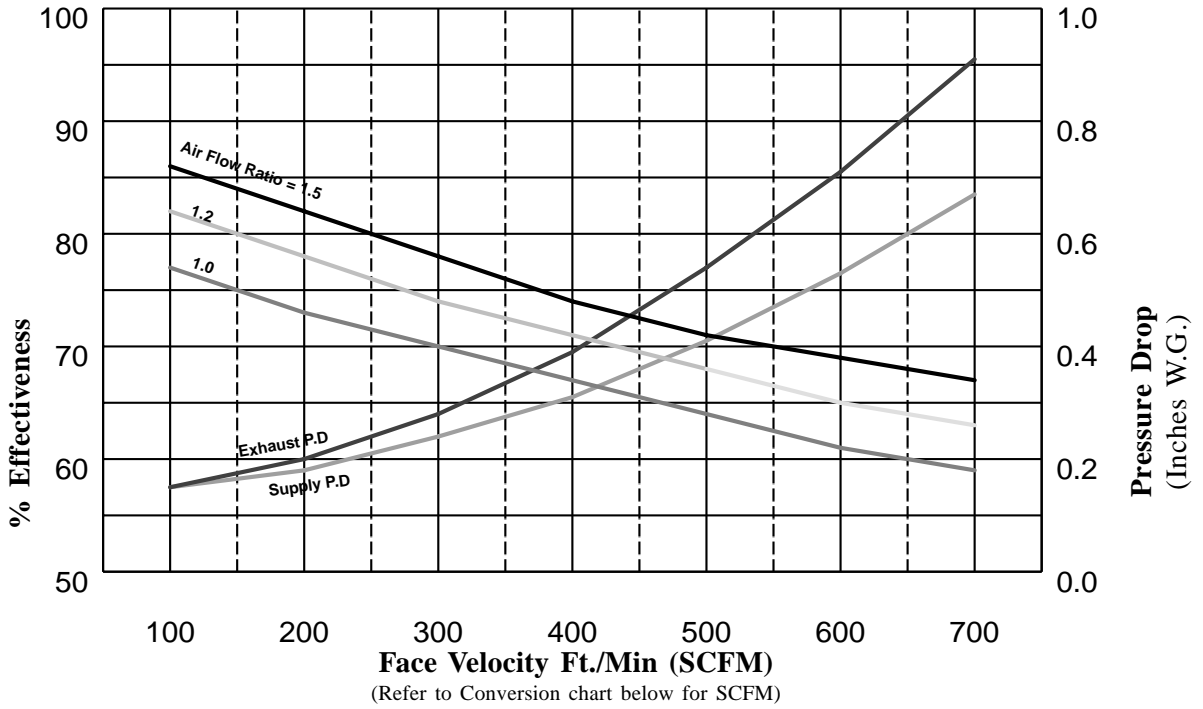

Conversion Chart - Airflow (SCFM) @ (Face Velocity x Face Area)

Size	(B) Length	(AxB) Face Area Sq. Ft.	Element Face Velocity							Wgt.
			100 ft/min	200 ft/min	300 ft/min	400 ft/min	500 ft/min	600 ft/min	700 ft/min	
X20A-10	9.84	1.15	115	230	345	459	574	689	804	25
X20A-18	17.72	2.17	217	434	651	868	1085	1303	1520	41
X20A-24	23.62	2.94	294	588	881	1175	1469	1763	2057	51
X20A-30	29.53	3.70	370	741	1111	1482	1852	2223	2593	60
X20A-36	35.43	4.47	447	894	1342	1789	2236	2683	3130	70
X20A-48	47.25	6.01	601	1201	1802	2402	3003	3603	4204	101
X20A-60	59.06	7.54	754	1508	2262	3016	3770	4524	5278	121
X20A-72	70.87	9.07	907	1815	2722	3629	4537	5444	6351	141

Performance curves are based on standard conditions. For specific entering conditions, refer to Selection Procedures, pages 12 through 19.

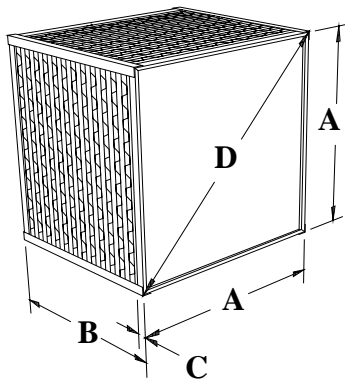

A = 19.7" (Height)
 C = 1.0" (Flange Dimension)
 D = 27.9"

Specifications and Dimensions are subject to change without notice.
 Rev. 11/95



Flat Plate Heat Exchanger Performance Curves

X20B ELEMENT

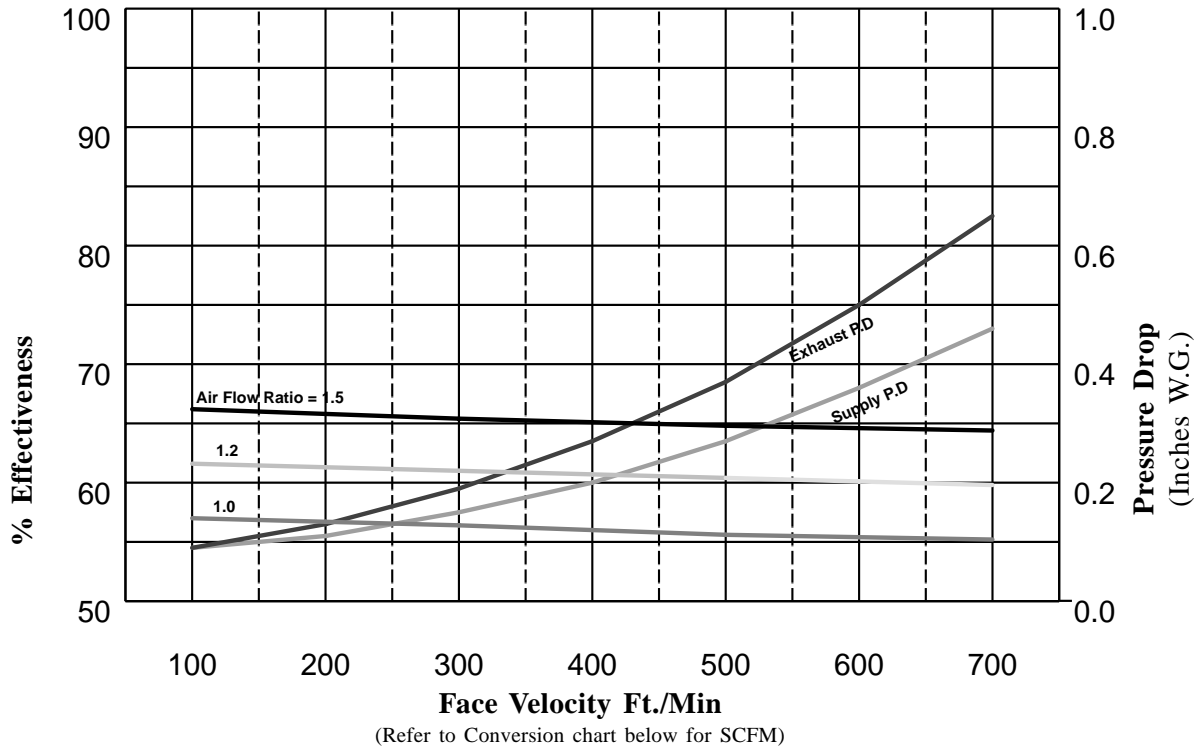

Conversion Chart - Airflow (SCFM) @ (Face Velocity x Face Area)

Size	(B) Length	(AxB) Face Area Sq. Ft.	Element Face Velocity							Wgt.
			100 ft/min	200 ft/min	300 ft/min	400 ft/min	500 ft/min	600 ft/min	700 ft/min	
X20B-10	9.84	1.15	115	230	345	459	574	689	804	33
X20B-18	17.72	2.17	217	434	651	868	1085	1303	1520	49
X20B-24	23.62	2.94	294	588	881	1175	1469	1763	2057	64
X20B-30	29.53	3.70	370	741	1111	1482	1852	2223	2593	79
X20B-36	35.43	4.47	447	894	1342	1789	2236	2683	3130	92
X20B-48	47.25	6.01	601	1201	1802	2402	3003	3603	4204	120
X20B-60	59.06	7.54	754	1508	2262	3016	3770	4524	5278	145
X20B-72	70.87	9.07	907	1815	2722	3629	4537	5444	6351	171

Performance curves are based on standard conditions. For specific entering conditions, refer to Selection Procedures, pages 12 through 19.

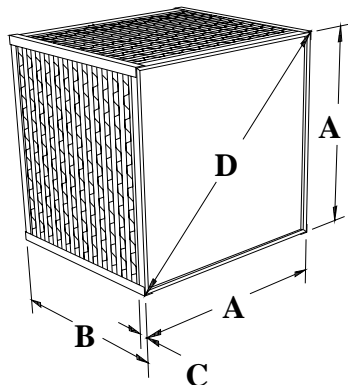

A = 19.7" (Height)
 C = 1.0" (Flange Dimension)
 D = 27.9"

Specifications and Dimensions are subject to change without notice.
 Rev. 11/95



Flat Plate Heat Exchanger Performance Curves

X24B ELEMENT

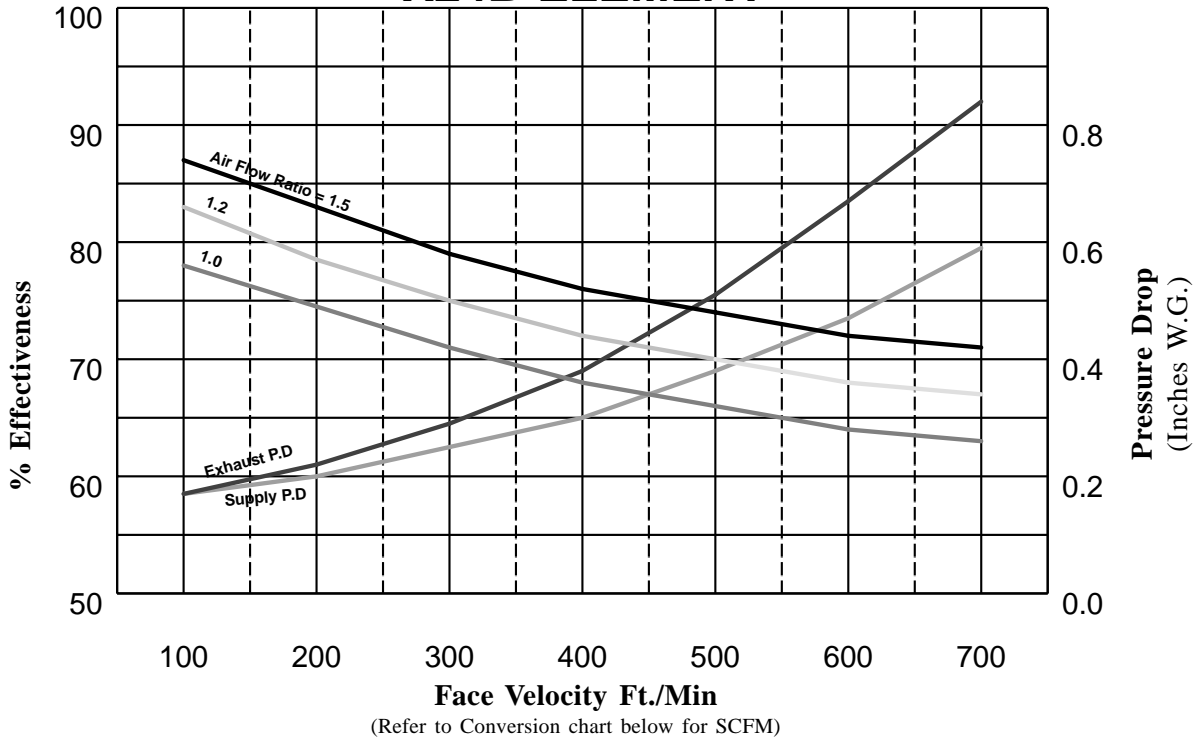

Conversion Chart - Airflow (SCFM) @ (Face Velocity x Face Area)

Size	(B) Length	(AxB) Face Area Sq. Ft.	Element Face Velocity							Wgt
			100 ft/min	200 ft/min	300 ft/min	400 ft/min	500 ft/min	600 ft/min	700 ft/min	
X24B-12	11.81	1.70	170	339	509	679	848	1018	1188	40
X24B-18	17.72	2.62	262	525	787	1049	1312	1574	1837	61
X24B-24	23.62	3.55	355	710	1065	1420	1775	2130	2485	80
X24B-30	29.53	4.48	448	895	1343	1791	2239	2686	3134	98
X24B-36	35.43	5.40	540	1081	1621	2162	2702	3243	3783	115
X24B-48	47.25	7.26	726	1452	2177	2903	3629	4355	5081	149
X24B-60	59.06	9.11	911	1822	2734	3645	4556	5467	6378	181
X24B-72	70.87	10.97	1097	2193	3290	4386	5483	6579	7676	213

Performance curves are based on standard conditions. For specific entering conditions, refer to Selection Procedures, pages 12 through 19.

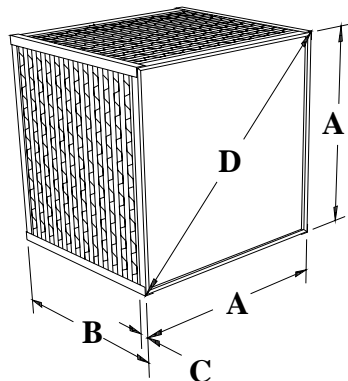

A = 23.6" (Height)
 C = 1.0" (Flange Dimension)
 D = 33.4"

Specifications and Dimensions are subject to change without notice.
 Rev. 11/95



Flat Plate Heat Exchanger Performance Curves

X24D ELEMENT

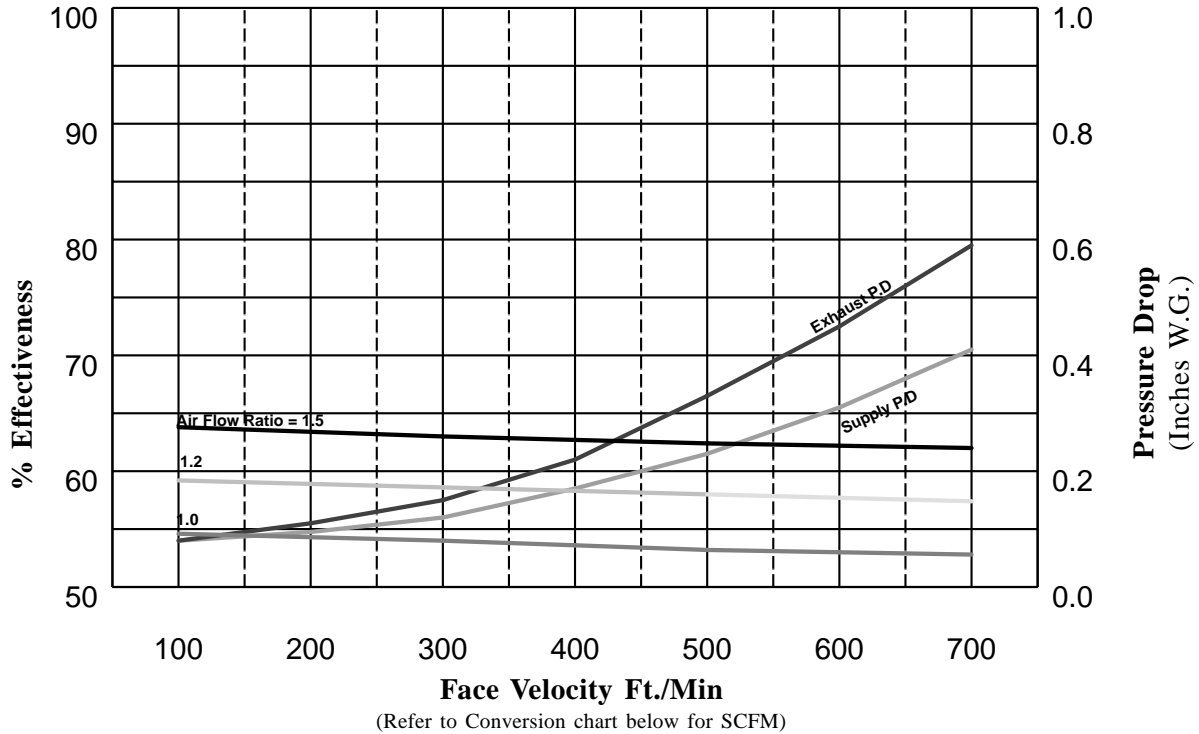

Conversion Chart - Airflow (SCFM) @ (Face Velocity x Face Area)

Size	(B) Length	(AxB) Face Area Sq. Ft.	Element Face Velocity							Wgt.
			100 ft/min	200 ft/min	300 ft/min	400 ft/min	500 ft/min	600 ft/min	700 ft/min	
X24D-12	11.81	1.70	170	339	509	679	848	1018	1188	33
X24D-18	17.72	2.62	262	525	787	1049	1312	1574	1837	49
X24D-24	23.62	3.55	355	710	1065	1420	1775	2130	2485	64
X24D-30	29.53	4.48	448	895	1343	1791	2239	2686	3134	79
X24D-36	35.43	5.40	540	1081	1621	2162	2702	3243	3783	92
X24D-48	47.25	7.26	726	1452	2177	2903	3629	4355	5081	120
X24D-60	59.06	9.11	911	1822	2734	3645	4556	5467	6378	145
X24D-72	70.87	10.97	1097	2193	3290	4386	5483	6579	7676	171

Performance curves are based on standard conditions. For specific entering conditions, refer to Selection Procedures, pages 12 through 19.



A = 23.6" (Height)
 C = 1.0" (Flange Dimension)
 D = 33.4"

Specifications and Dimensions are subject to change without notice.
 Rev. 11/95

Flat Plate Heat Exchanger Performance Curves X30B ELEMENT

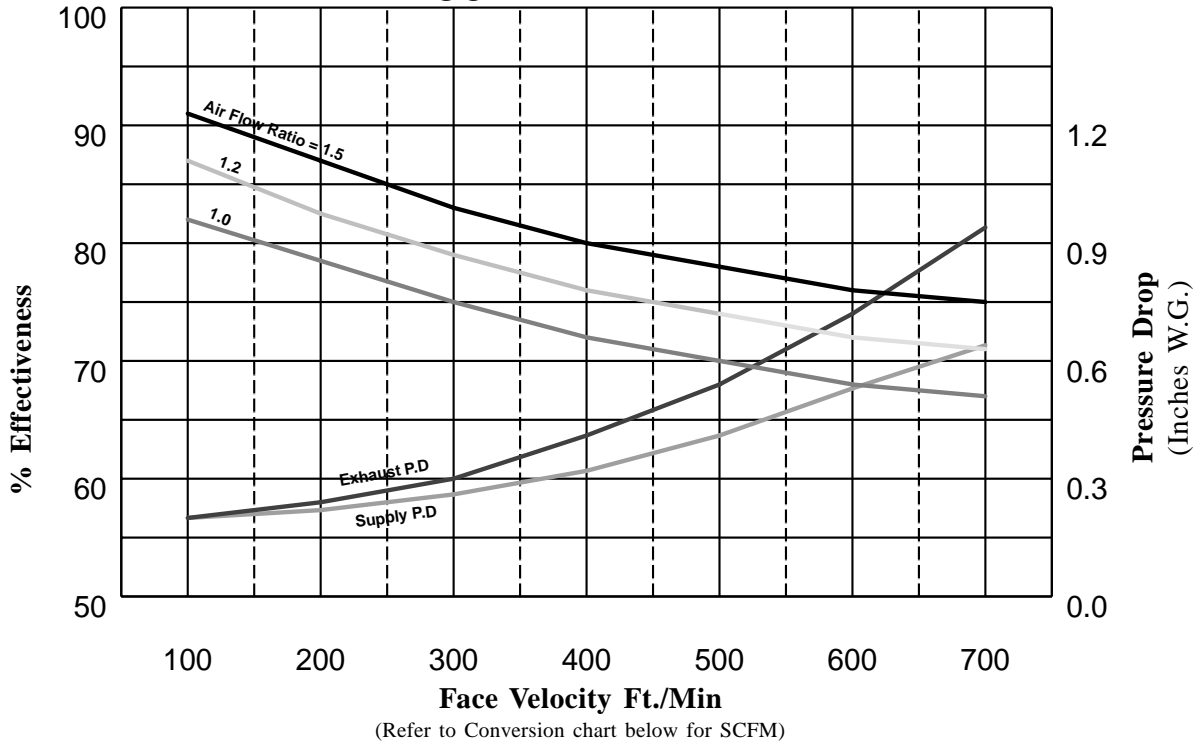

Conversion Chart - Airflow (SCFM) @ (Face Velocity x Face Area)

Size	(B) Length	(AxB) Face Area Sq. Ft.	Element Face Velocity							Wgt.
			100 ft/min	200 ft/min	300 ft/min	400 ft/min	500 ft/min	600 ft/min	700 ft/min	
X30B-18	17.72	3.31	331	662	993	1323	1654	1985	2316	112
X30B-24	23.62	4.48	448	896	1343	1791	2239	2687	3134	150
X30B-30	29.53	5.65	565	1129	1694	2259	2823	3388	3952	184
X30B-36	35.43	6.82	682	1363	2045	2726	3408	4089	4771	224
X30B-42	41.34	7.98	798	1597	2395	3194	3992	4790	5589	262
X30B-48	47.25	9.15	915	1831	2746	3661	4576	5492	6407	299
X30B-60	59.06	11.49	1149	2298	3447	4596	5745	6894	8043	374
X30B-72	70.87	13.83	1383	2766	4149	5531	6914	8297	9680	449

Performance curves are based on standard conditions. For specific entering conditions, refer to Selection Procedures, pages 12 through 19.

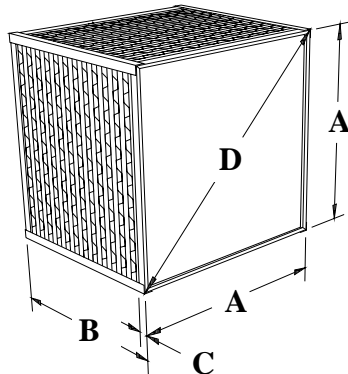

A = 29.5" (Height)
C = 1.0" (Flange Dimension)
D = 41.7"

Specifications and Dimensions are subject to change without notice.
Rev. 11/95



Flat Plate Heat Exchanger Performance Curves

X30D ELEMENT

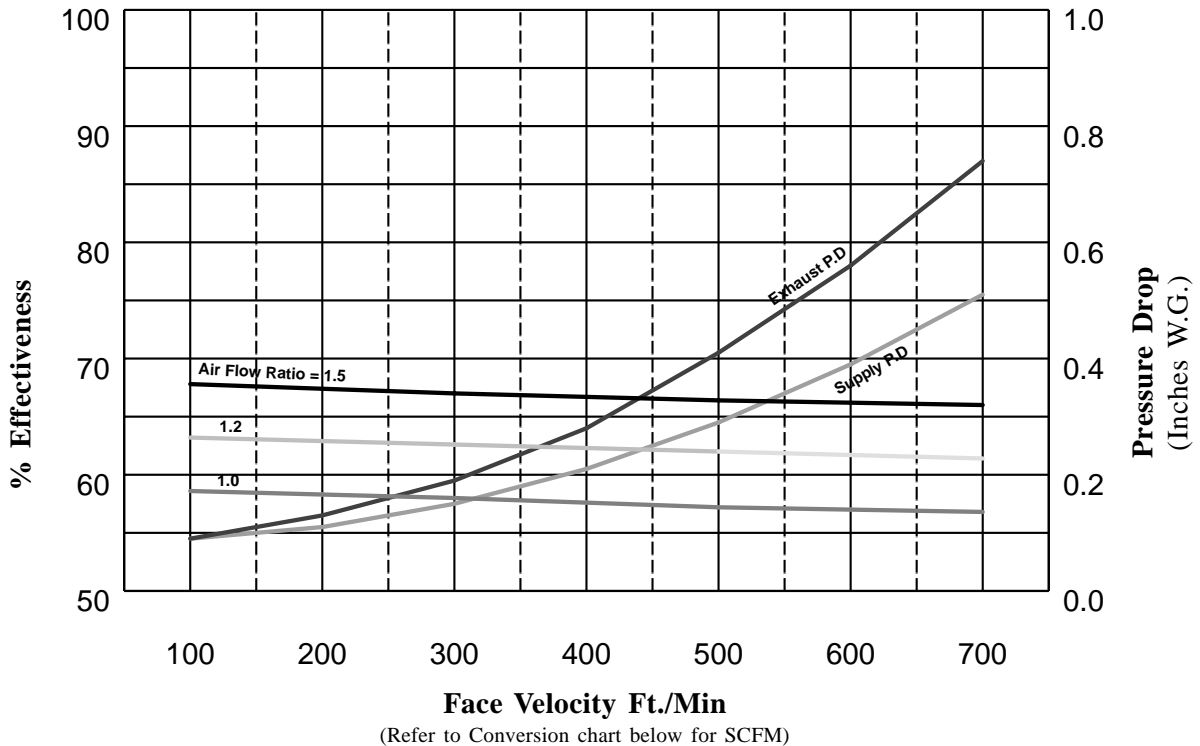

Conversion Chart - Airflow (SCFM) @ (Face Velocity x Face Area)

Size	(B) Length	(AxB) Face Area Sq. Ft.	Element Face Velocity							Wgt.
			100 ft/min	200 ft/min	300 ft/min	400 ft/min	500 ft/min	600 ft/min	700 ft/min	
X30D-18	17.72	3.31	331	662	993	1323	1654	1985	2316	77
X30D-24	23.62	4.48	448	896	1343	1791	2239	2687	3134	103
X30D-30	29.53	5.65	565	1129	1694	2259	2823	3388	3952	154
X30D-36	35.43	6.82	682	1363	2045	2726	3408	4089	4771	180
X30D-42	41.34	7.98	798	1597	2395	3194	3992	4790	5589	205
X30D-48	47.25	9.15	915	1831	2746	3661	4576	5492	6407	231
X30D-60	59.06	11.49	1149	2298	3447	4596	5745	6894	8043	257
X30D-72	70.87	13.83	1383	2766	4149	5531	6914	8297	9680	308

Performance curves are based on standard conditions. For specific entering conditions, refer to Selection Procedures, pages 12 through 19.

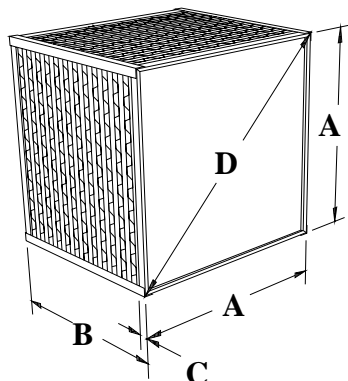

A = 29.5" (Height)
 C = 1.0" (Flange Dimension)
 D = 41.7"

Specifications and Dimensions are subject to change without notice.
 Rev. 11/95

Flat Plate Heat Exchanger Performance Curves

X40B ELEMENT

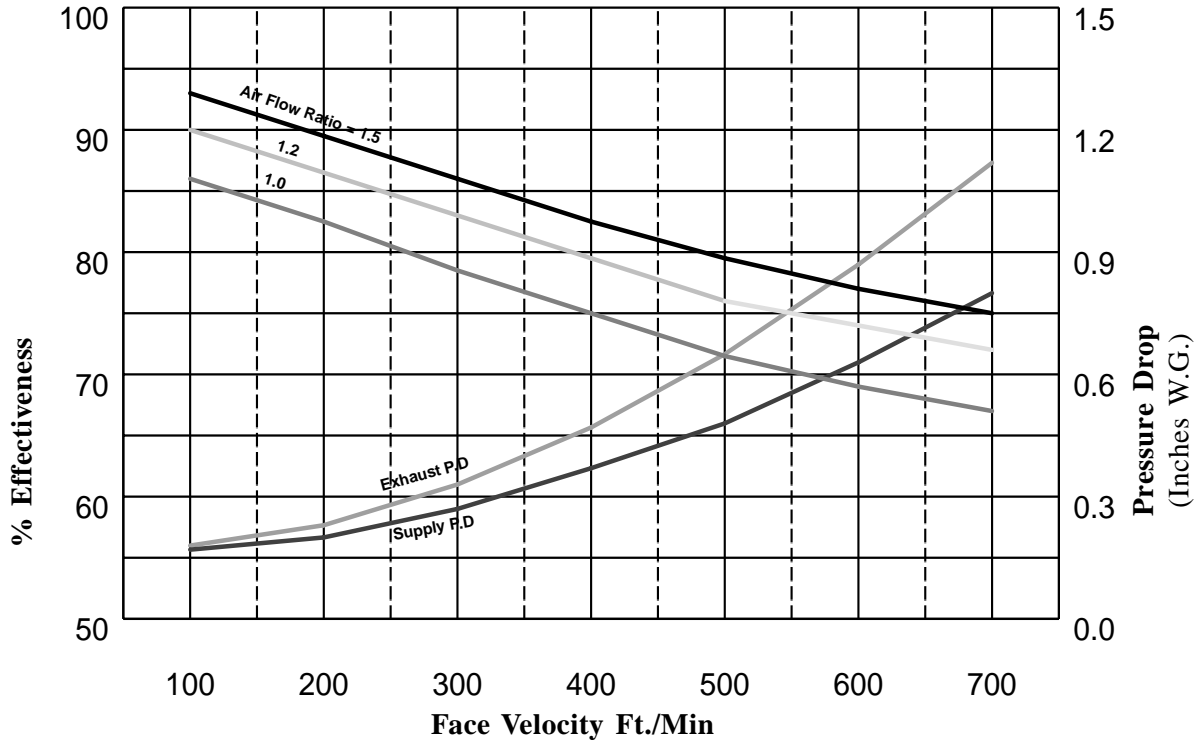

(Refer to Conversion chart below for SCFM)

Conversion Chart - Airflow (SCFM) @ (Face Velocity x Face Area)

Size	(B) Length	(AxB) Face Area Sq. Ft.	Element Face Velocity							Wgt.
			100 ft/min	200 ft/min	300 ft/min	400 ft/min	500 ft/min	600 ft/min	700 ft/min	
X40B-18	17.72	4.46	446	892	1337	1783	2229	2675	3121	173
X40B-24	23.62	6.03	603	1207	1810	2413	3016	3620	4223	231
X40B-30	29.53	7.61	761	1522	2282	3043	3804	4565	5325	289
X40B-36	35.43	9.18	918	1837	2755	3673	4591	5510	6428	347
X40B-42	41.34	10.76	1076	2151	3227	4303	5379	6454	7530	405
X40B-48	47.25	12.33	1233	2466	3700	4933	6166	7399	8633	462
X40B-60	59.06	15.48	1548	3096	4645	6193	7741	9289	10837	578
X40B-72	70.87	18.63	1863	3726	5590	7453	9316	11179	13042	693

Performance curves are based on standard conditions. For specific entering conditions, refer to Selection Procedures, pages 12 through 19.

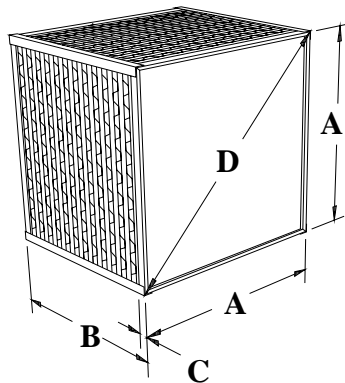

A = 41.3" (Height)
 C = 1.5" (Flange Dimension)
 D = 58.5"

Specifications and Dimensions are subject to change without notice.
 Rev. 11/95



Flat Plate Heat Exchanger Performance Curves

X40D ELEMENT

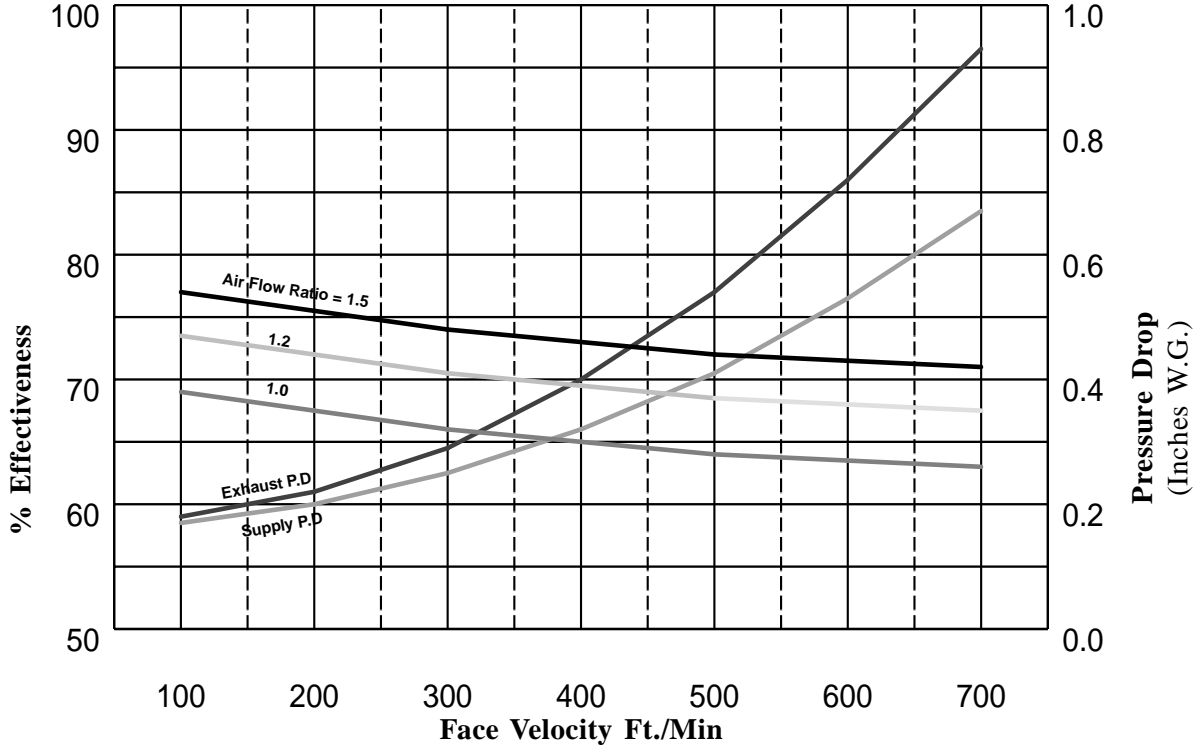

(Refer to Conversion chart below for SCFM)

Conversion Chart - Airflow (SCFM) @ (Face Velocity x Face Area)

Size	(B) Length	(AxB) Face Area Sq. Ft.	Element Face Velocity							Wgt.
			100 ft/min	200 ft/min	300 ft/min	400 ft/min	500 ft/min	600 ft/min	700 ft/min	
X40D-18	17.72	4.46	446	892	1337	1783	2229	2675	3121	134
X40D-24	23.62	6.03	603	1207	1810	2413	3016	3620	4223	178
X40D-30	29.53	7.61	761	1522	2282	3043	3804	4565	5325	223
X40D-36	35.43	9.18	918	1837	2755	3673	4591	5510	6428	268
X40D-42	41.34	10.76	1076	2151	3227	4303	5379	6454	7530	312
X40D-48	47.25	12.33	1233	2466	3700	4933	6166	7399	8633	357
X40D-60	59.06	15.48	1548	3096	4645	6193	7741	9289	10837	446
X40D-72	70.87	18.63	1863	3726	5590	7453	9316	11179	13042	535

Performance curves are based on standard conditions. For specific entering conditions, refer to Selection Procedures, pages 12 through 19.

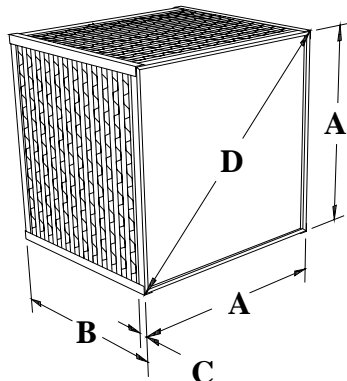

A = 41.3" (Height)
 C = 1.5" (Flange Dimension)
 D = 58.5"

Specifications and Dimensions are subject to change without notice.
 Rev. 11/95

Flat Plate Heat Exchanger Performance Curves

X50B ELEMENT

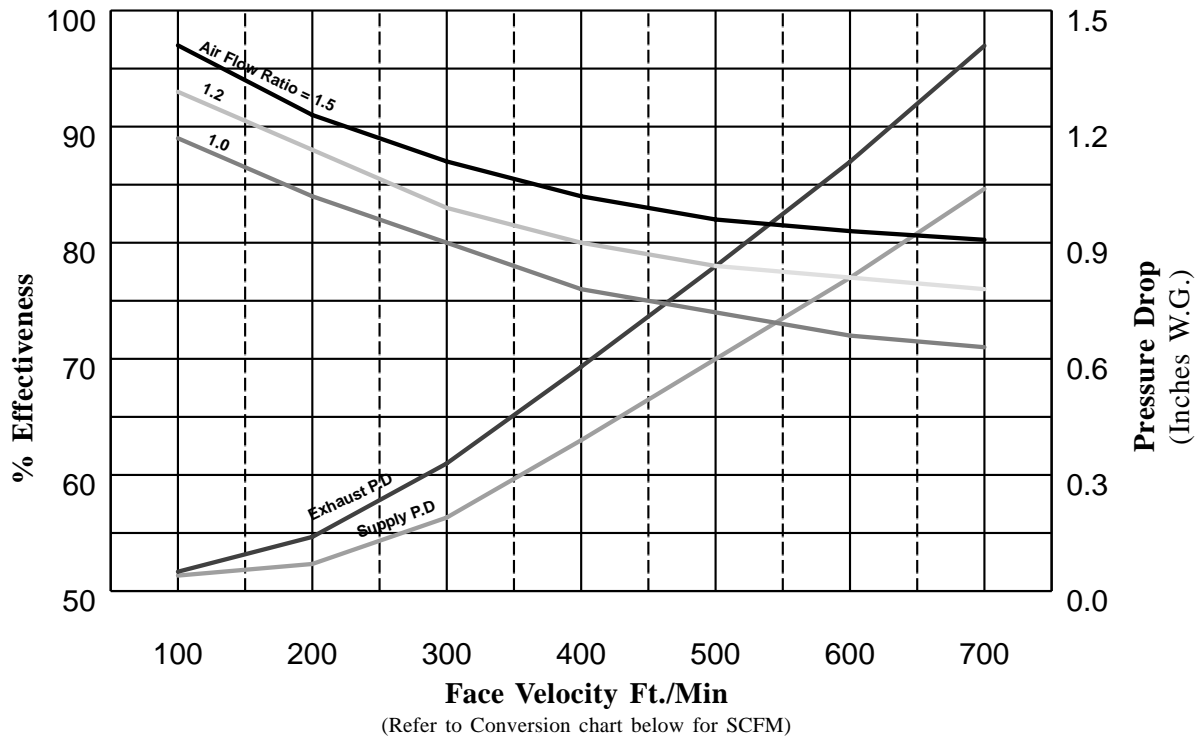

Conversion Chart - Airflow (SCFM) @ (Face Velocity x Face Area)

Size	(B) Length	(AxB) Face Area Sq. Ft.	Element Face Velocity							Wgt.
			100 ft/min	200 ft/min	300 ft/min	400 ft/min	500 ft/min	600 ft/min	700 ft/min	
X50B-24	23.62	7.33	703	1405	2108	2811	3514	4216	4919	324
X50B-36	35.43	11.24	1078	2156	3234	4312	5390	6468	7546	485
X50B-48	47.25	15.15	1453	2906	4359	5813	7266	8719	10172	648
X50B-60	59.06	19.07	1828	3657	5485	7313	9142	10970	12798	809
X50B-72	70.87	22.98	2204	4407	6611	8814	11018	13221	15425	971
X50B-84	82.68	26.89	2579	5157	7736	10315	12894	15472	18051	1134
X50B-96	94.49	30.80	2954	5908	8862	11816	14770	17724	20678	1295
X50B-108	106.30	33.29	3329	6658	9987	13317	16646	19975	23304	1456

Performance curves are based on standard conditions. For specific entering conditions, refer to Selection Procedures, pages 12 through 19.

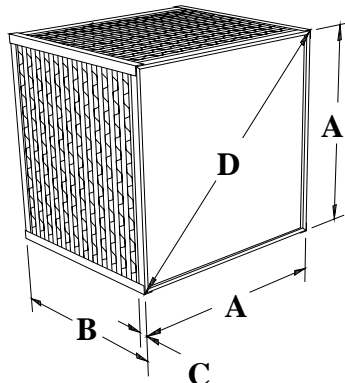

A = 49.2" (Height)
 C = 1.5" (Flange Dimension)
 D = 69.6"

Specifications and Dimensions are subject to change without notice.
 Rev. 11/95



Flat Plate Heat Exchanger Performance Curves

X50D ELEMENT

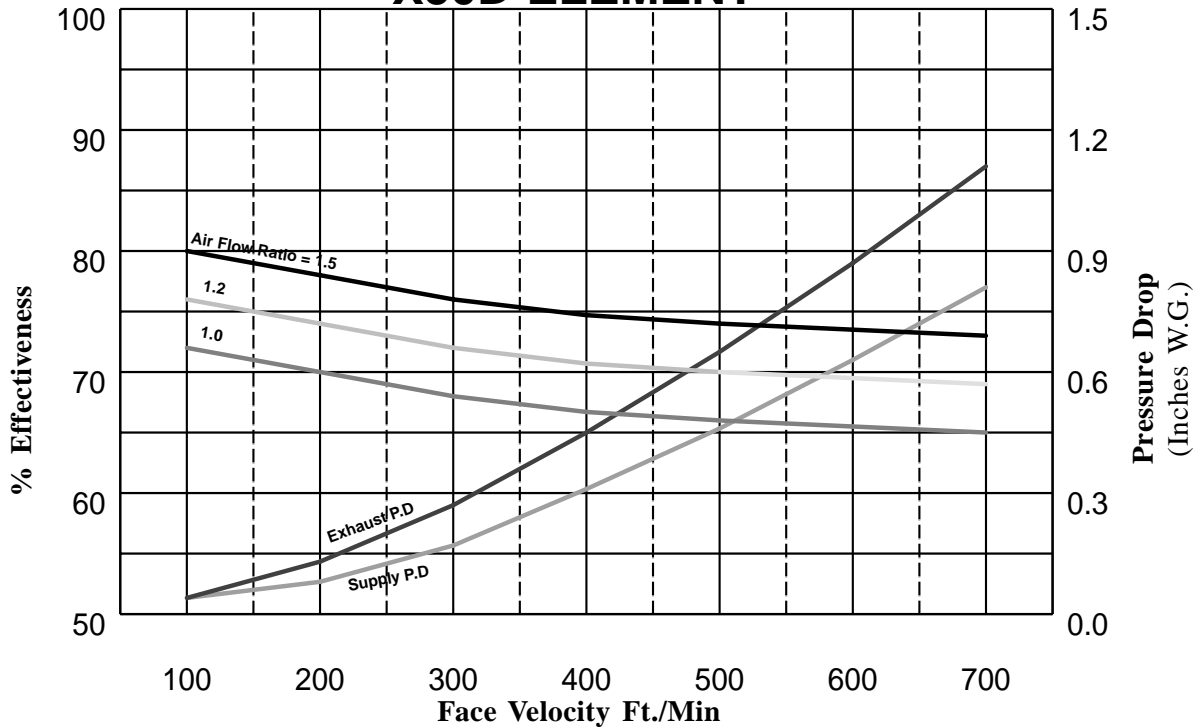

(Refer to Conversion chart below for SCFM)

Conversion Chart - Airflow (SCFM) @ (Face Velocity x Face Area)

Size	(B) Length	(AxB) Face Area Sq. Ft.	Element Face Velocity							Wgt.
			100 ft/min	200 ft/min	300 ft/min	400 ft/min	500 ft/min	600 ft/min	700 ft/min	
X50D-24	23.62	7.33	703	1405	2108	2811	3514	4216	4919	251
X50D-36	35.43	11.24	1078	2156	3234	4312	5390	6468	7546	376
X50D-48	47.25	15.15	1453	2906	4359	5813	7266	8719	10172	502
X50D-60	59.06	19.07	1828	3657	5485	7313	9142	10970	12798	627
X50D-72	70.87	22.98	2204	4407	6611	8814	11018	13221	15425	752
X50D-84	82.68	26.89	2579	5157	7736	10315	12894	15472	18051	878
X50D-96	94.49	30.80	2954	5908	8862	11816	14770	17724	20678	1003
X50D-108	106.30	33.29	3329	6658	9987	13317	16646	19975	23304	1128

Performance curves are based on standard conditions. For specific entering conditions, refer to Selection Procedures, pages 12 through 19.

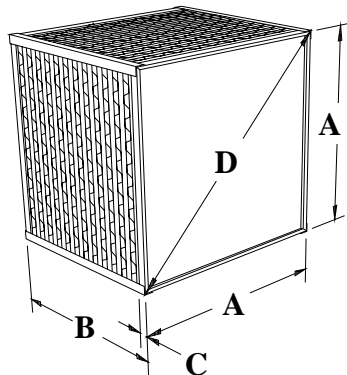

A = 49.2" (Height)
 C = 1.5" (Flange Dimension)
 D = 69.6"

Specifications and Dimensions are subject to change without notice.
 Rev. 11/95

Flat Plate Heat Exchanger Performance Curves

X60D ELEMENT

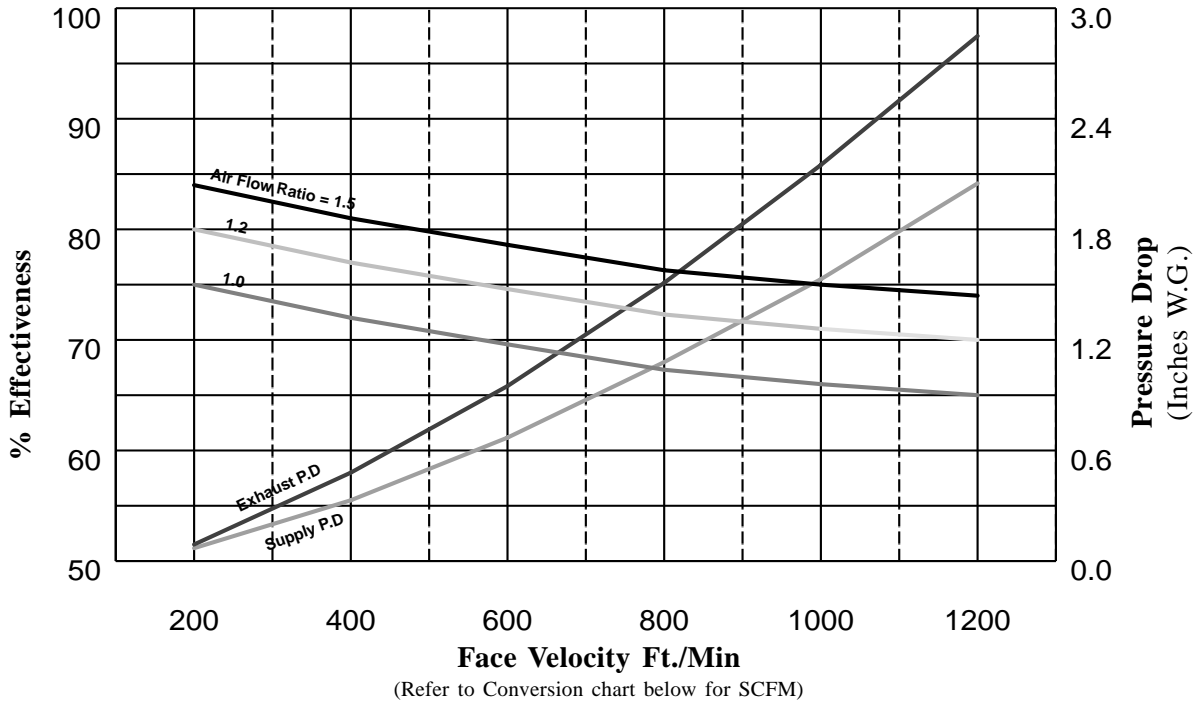

Conversion Chart - Airflow (SCFM) @ (Face Velocity x Face Area)

Size	(B) Length	(AxB) Face Area Sq. Ft.	Element Face Velocity						Wgt.
			200 ft/min	400 ft/min	600 ft/min	800 ft/min	1000 ft/min	1200 ft/min	
X60D-24	23.62	8.56	1712	3424	5136	6847	8559	10271	411
X60D-36	35.43	13.23	2647	5294	7941	10588	13235	15882	616
X60D-48	47.25	17.91	3582	7164	10746	14328	17910	21492	822
X60D-60	59.06	22.59	4517	9034	13551	18068	22585	27103	1027
X60D-72	70.87	27.26	5452	10904	16357	21809	27261	32713	1232
X60D-84	82.68	31.94	6387	12775	19162	25549	31936	38324	1438
X60D-96	94.49	36.61	7322	14645	21967	29289	36612	43934	1643
X60D-108	106.30	41.29	8257	16515	24772	33030	41287	49545	1848

Performance curves are based on standard conditions. For specific entering conditions, refer to Selection Procedures, pages 12 through 19.

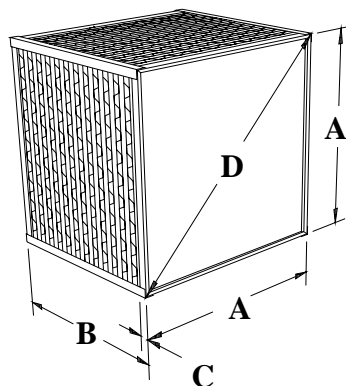

A = 59.0" (Height)
 C = 1.0" (Flange Dimension)
 D = 83.4"

Specifications and Dimensions are subject to change without notice.
 Rev. 11/95



Flat Plate Heat Exchanger Performance Curves

X80D ELEMENT

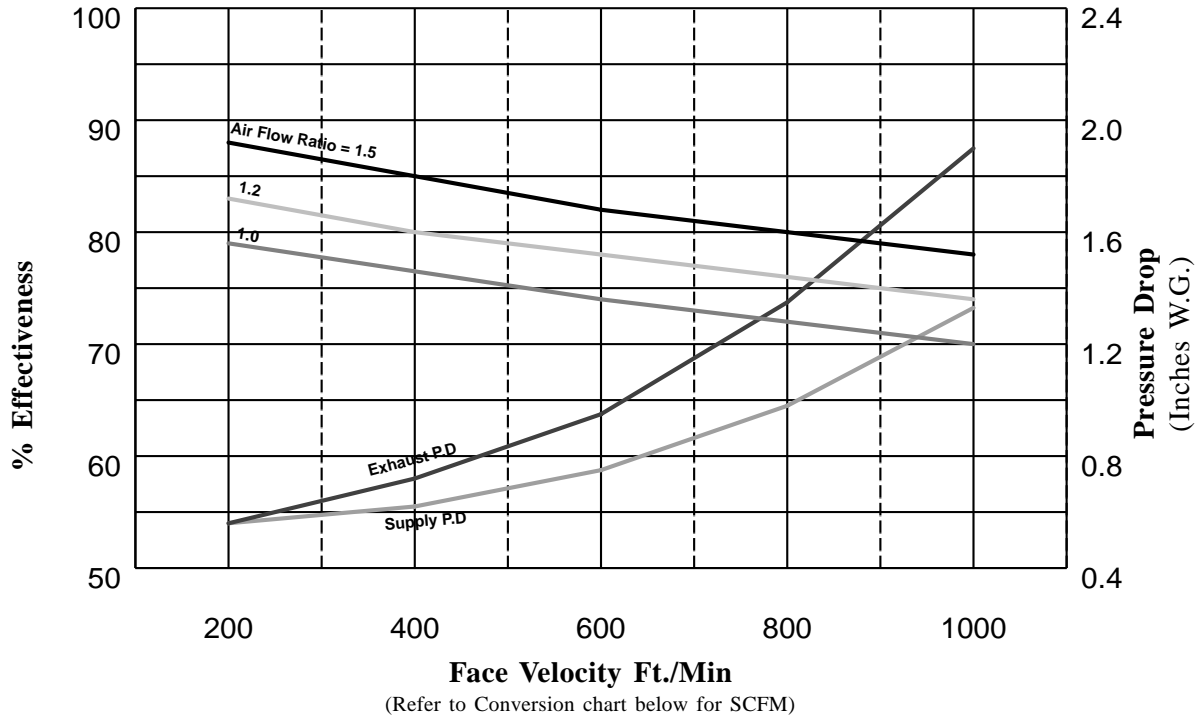

Conversion Chart - Airflow (SCFM) @ (Face Velocity x Face Area)

Size	(B) Length	(AxB) Face Area Sq. Ft.	Element Face Velocity					Wgt.
			200 ft/min	400 ft/min	600 ft/min	800 ft/min	1000 ft/min	
X80D-48	47.25	23.71	4742	9484	14226	18968	23709	1736
X80D-60	59.06	29.97	5994	11987	17981	23974	29968	2170
X80D-72	70.87	36.23	7245	14491	21736	28981	36226	2605
X80D-84	82.68	42.48	8497	16994	25491	33988	42485	3038
X80D-96	94.49	48.74	9749	19497	29246	38995	48743	3473
X80D-108	106.30	55.00	11000	22001	33001	44002	55002	3906
X80D-120	118.12	61.12	12240	24480	36730	48970	61200	4340
X80D-144	143.70	74.76	14950	29900	44860	54810	74760	5208

Performance curves are based on standard conditions. For specific entering conditions, refer to Selection Procedures, pages 12 through 19.

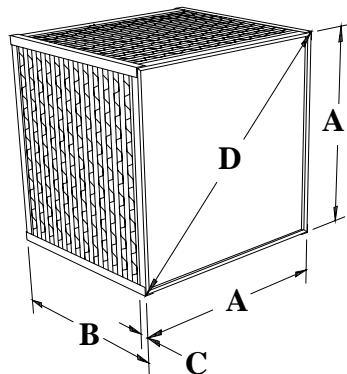

A = 78.8" (Height)
 C = 1.5" (Flange Dimension)
 D = 111.4"

Specifications and Dimensions are subject to change without notice.
 Rev. 11/95



General Specification

Furnish a "Heat-X-Changer" stationary flat plate air-to-air heat exchanger manufactured by XeteX, Inc. Heat transfer surface shall be pressed and formed aluminum plates with corrugated aluminum spacers capable of withstanding a pressure difference between airflows of 10" w.g. without deforming air passages. The airflow passages shall provide maximum surface area for enhanced heat transfer with laminar airflow for low pressure drops. Exchanger cell shall be virtually "crush-proof" and be capable of being installed vertically or horizontally without crushing or settling of the individual plates. Unit shall be capable of operating in temperatures up to 220°F. The sealing surface between plates shall have a minimum width of 5 times the plate separation distance. Exposed folded/crimped edges are not acceptable. Standard cell construction shall have a maximum cross contamination between airflows of 0.01% of total airflow. The entire cell shall be capable of being visibly inspected and cleaned as required. Heat exchanger performance shall be certified, with documentation, by an independent test laboratory.

Optional Coatings and Materials

Baked Epoxy for extended cell life in highly corrosive conditions.

A baked epoxy coating shall be applied to both sides of the aluminum sheets prior to assembly.

Heresite Coating for maximum cell protection in corrosive conditions.

A Heresite coating shall be applied to the assembled cell to provide complete corrosion protection to cell material.

Xseal - an exclusive epoxy sealant for absolute leak protection and cell rigidity.

The completed exchanger cell shall be dipped in an epoxy sealant (Xseal) to provide an absolute seal between airflows and increased cell rigidity.

Materials for special conditions.

Exchanger cell shall be constructed of stainless steel, galvanized steel or phenolic aluminum.



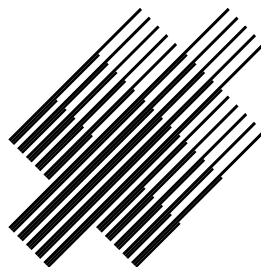

XeteX, Inc.
3530 East 28th Street
Minneapolis, MN 55406
(612) 724-3101
(612) 721-6303